



# STARTUP FINANCE



## LEARNING OUTCOMES

After going through the chapter student shall be able to understand:

- Introduction of Startup finance
- Pitch Presentation
- Sources of Funding
- Startup financing through Venture Capital Financing

### 1. THE BASICS OF STARTUP FINANCING

Startup financing means some initial infusion of money needed to turn an idea (by starting a business) into reality. While starting out, big lenders like banks etc. are not interested in a startup business. The reason is that when you are just starting out, you're not at the point yet where a traditional lender or investor would be interested in you. So that leaves one with the option of selling some assets, borrowing against one's home, asking loved ones i.e. family and friends for loans etc. But that involves a lot of risk, including the risk of bankruptcy and strained relationships with friends and family.

So, the pertinent question is how to keep loans from family and friends strictly business like. This is the hard part behind starting a business -- putting so much at risk but doing so is essential. It's what sets entrepreneurs apart from people who collect regular salaries as employees.

A good way to get success in the field of entrepreneurship is to speed up initial operations as quickly as possible to get to the point where outside investors can see and feel the business venture, as well as understand that a person has taken some risk reaching it to that level.

Some businesses can also be bootstrapped (attempting to found and build a company from personal finances or from the operating revenues of the new company). They can be built up quickly enough to make money without any help from investors who might otherwise come in and start dictating the terms.

In order to successfully launch a business and get it to a level where large investors are interested in putting their money, requires a strong business plan. It also requires seeking advice from experienced entrepreneurs and experts -- people who might invest in the business sometime in the future.



## 2. SOME OF THE INNOVATIVE WAYS TO FINANCE A STARTUP

Every startup needs access to capital, whether for funding product development, acquiring machinery and inventory or paying salaries to its employee. Most entrepreneurs think first of bank loans as the primary source of money, only to find out that banks are really the least likely benefactors for startups. So, innovative measures include maximizing non-bank financing.

Here are some of the sources for funding a startup:

- (i) **Personal financing:** It may not seem to be innovative but you may be surprised to note that most budding entrepreneurs never thought of saving any money to start a business. This is important because most of the investors will not put money into a deal if they see that you have not contributed any money from your personal sources.
- (ii) **Personal credit lines:** One qualifies for personal credit line based on one's personal credit efforts. Credit cards are a good example of this. However, banks are very cautious while granting personal credit lines. They provide this facility only when the business has enough cash flow to repay the line of credit.
- (iii) **Family and friends:** These are the people who generally believe in you, without even thinking that your idea works or not. However, the loan obligations to friends and relatives should always be in writing as a promissory note or otherwise.
- (iv) **Peer-to-peer lending:** In this process group of people come together and lend money to each other. Peer to peer lending has been there for many years. Many small and ethnic business groups having similar faith or interest generally support each other in their start up endeavors.
- (v) **Crowdfunding:** Crowdfunding is the use of small amounts of capital from a large number of individuals to finance a new business initiative. Crowdfunding makes use of the easy accessibility

of vast networks of people through social media and crowdfunding websites to bring investors and entrepreneurs together.

**(vi) Microloans:** Microloans are small loans that are given by individuals at a lower interest to a new business ventures. These loans can be issued by a single individual or aggregated across a number of individuals who each contribute a portion of the total amount.

**(vii) Vendor financing:** Vendor financing is the form of financing in which a company lends money to one of its customers so that he can buy products from the company itself. Vendor financing also takes place when many manufacturers and distributors are convinced to defer payment until the goods are sold. This means extending the payment terms to a longer period for e.g. 30 days payment period can be extended to 45 days or 60 days. However, this depends on one's credit worthiness and payment of more money.

**(viii) Purchase order financing:** The most common scaling problem faced by startups is the inability to find a large new order. The reason is that they don't have the necessary cash to produce and deliver the product. Purchase order financing companies often advance the required funds directly to the supplier. This allows the completion of transaction and profit flows up to the new business.

**(ix) Factoring accounts receivables:** In this method, a facility is given to the seller who has sold the good on credit to fund his receivables till the amount is fully received. So, when the goods are sold on credit, and the credit period (i.e. the date upto which payment shall be made) is for example 6 months, factor will pay most of the sold amount up front and rest of the amount later. Therefore, in this way, a startup can meet his day to day expenses.

### 3. PITCH PRESENTATION

Pitch presentation is a short and brief presentation (not more than 20 minutes) to investors explaining about the prospects of the company and why they should invest into the startup business. So, pitch deck presentation is a brief presentation basically using PowerPoint to provide a quick overview of business plan and convincing the investors to put some money into the business. Pitch presentation can be made either during face to face meetings or online meetings with potential investors, customers, partners, and co-founders. Here, some of the methods have been highlighted below as how to approach a pitch presentation:

**(i) Introduction:** To start with, first step is to give a brief account of yourself i.e. who are you? What are you doing? But care should be taken to make it short and sweet. Also, use this opportunity to get your investors interested in your company. One can also talk up the most interesting facts about one's business, as well as any huge milestones one may have achieved.

**(ii) Team:** The next step is to introduce the audience the people behind the scenes. The reason is that the investors will want to know the people who are going to make the product or service successful. Moreover, the investors are not only putting money towards the idea but they

are also investing in the team. Also, an attempt should be made to include the background of the promoter, and how it relates to the new company. Moreover, if possible, it can also be highlighted that the team has worked together in the past and achieved significant results.

(iii) **Problem:** Further, the promoter should be able to explain the problem he is going to solve and solutions emerging from it. Further the investors should be convinced that the newly introduced product or service will solve the problem convincingly.

For instance, when Facebook was launched in 2004, it added some new features which give it a more professional and lively look in comparison to Orkut which was there for some time. It enabled Facebook to become an instant hit among the people. Further, customers have no privacy while using Orkut. However, in Facebook, you can view a person's profile only if he adds you to his list. These simple yet effective advantages that Facebook has over Orkut make it an extremely popular social networking site.

(iv) **Solution:** It is very important to describe in the pitch presentation as to how the company is planning to solve the problem. For instance, when Flipkart first started its business in 2007, it brought the concept of e-commerce in India but when they started, payment through credit card was rare. So, they introduced the system of payment on the basis of cash on delivery which was later followed by other e-commerce companies in India. The second problem was the entire supply chain system. Delivering goods on time is one of the most important factors that determine the success of an ecommerce company. Flipkart addressed this issue by launching their own supply chain management system to deliver orders in a timely manner. These innovative techniques used by Flipkart enabled them to raise large amount of capital from the investors.

(v) **Marketing/Sales:** This is a very important part where investors will be deeply interested. The market size of the product must be communicated to the investors. This can include profiles of target customers, but one should be prepared to answer questions about how the promoter is planning to attract the customers. If a business is already selling goods, the promoter can also brief the investors about the growth and forecast future revenue.

(vi) **Projections or Milestones:** It is true that it is difficult to make financial projections for a startup concern. If an organization doesn't have a long financial history, an educated guess can be made. Projected financial statements can be prepared which gives an organization a brief idea about where is the business heading? It tells us that whether the business will be making profit or loss?

Financial projections include three basic documents that make up a business's financial statements.

- **Income statement:** This projects how much money the business will generate by projecting income and expenses, such as sales, cost of goods sold, expenses and capital. For your first year in business, you'll want to create a monthly income statement. For the second

year, quarterly statements will suffice. For the following years, you'll just need an annual income statement.

- **Cash flow statement:** A projected cash flow statement will depict how much cash will be coming into the business and out of that cash how much cash will be utilized into the business. At the end of each period (e.g. monthly, quarterly, annually), one can tally it all up to show either a profit or loss.
- **Balance sheet:** The balance sheet shows the business's overall finances including assets, liabilities and equity. Typically, one will create an annual balance sheet for one's financial projections.

**(vii) Competition:** Every business organization has competition even if the product or service offered is new and unique. It is necessary to highlight in the pitch presentation as to how the products or services are different from their competitors. If any of the competitors have been acquired, their complete details like name of the organization, acquisition prices etc. should also be highlighted.

**(viii) Business Model:** The term business model is a wide term denoting core aspects of a business including purpose, business process, target customers, offerings, strategies, infrastructure, organizational structures, sourcing, trading practices, and operational processes and policies including culture.

Further, as per Investopedia, a business model is the way in which a company generates revenue and makes a profit from company operations. Analysts use the term gross profit as a way to compare the efficiency and effectiveness of a firm's business model. Gross profit is calculated by subtracting the cost of goods sold from revenues. A business model can be illustrated with the help of an example. There are two companies – company A and company B. Both the companies are engaged in the business of renting movies. Prior to the advent of internet both the companies rent movies physically. Both the companies made ₹ 5 crore as revenues. Cost of goods sold was ₹ 4 crore. So, the companies made ₹ 1 crore as gross profit. After the introduction of internet, company A started to offer movies online instead of renting or selling it physically. This change affected the business model of company A positively. Revenue is still ₹ 5 crore but the significant part is that cost of goods sold is now ₹ 2 crore only. This is because online sales lead to significant reduction of storage and distribution costs. So, the gross profit increases from 20% to 60%.

Therefore, Company A isn't making more in sales, but it figured out a way to revolutionize its business model, which greatly reduces costs. Managers at company A have an additional 40% more in margin to play with than managers at company A. Managers at company A have little room for error and they have to tread carefully.

Hence, every investor wants to get his money back, so it's important to tell them in a pitch presentation as to how they should plan on generating revenue. It is better to show the investors a list of the various revenue streams for a business model and the timeline for each of them. Further, how to price the product and what does the competitor charge for the same or similar product shall

also be highlighted. It is also beneficial to discuss the lifetime value of the customer and what should be the strategy to keep him glued to their product.

**(ix) Financing:** If a startup business firm has raised money, it is preferable to talk about how much money has already been raised, who invested money into the business and what they did about it. If no money has been raised till date, an explanation can be made regarding how much work has been accomplished with the help of minimum funding that the company is managed to raise.

It is true that investors like to see entrepreneurs who have invested their own money. If a promoter is pitching to raise capital he should list how much he is looking to raise and how he intend to use the funds.



## 4. MODES OF FINANCING FOR STARTUPS

**(i) Bootstrapping :** An individual is said to be boot strapping when he or she attempts to found and build a company from personal finances or from the operating revenues of the new company.

A common mistake made by most founders is that they make unnecessary expenses towards marketing, offices and equipment they cannot really afford. So, it is true that more money at the inception of a business leads to complacency and wasteful expenditure. On the other hand, investment by startups from their own savings leads to cautious approach. It curbs wasteful expenditures and enable the promoter to be on their toes all the time.

Here are some of the methods in which a startup firm can bootstrap:

**(a) Trade Credit:** When a person is starting his business, suppliers are reluctant to give trade credit. They will insist on payment of their goods supplied either by cash or by credit card. However, a way out in this situation is to prepare a well-crafted financial plan. The next step is to pay a visit to the supplier's office. If the business organization is small, the owner can be directly contacted. On the other hand, if it is a big firm, the Chief Financial Officer can be contacted and convinced about the financial plan.

Communication skills are important here. The financial plan has to be shown. The owner or the financial officer has to be explained about the business and the need to get the first order on credit in order to launch the venture. The owner or financial officer may give half the order on credit and balance on delivery. The trick here is to get the goods shipped and sell them before paying to them. One can also borrow to pay for the good sold but there is interest cost also. So trade credit is one of the most important way to reduce the amount of working capital one needs. This is especially true in retail operations.

When you visit your supplier to set up your order during your startup period, ask to speak directly to the owner of the business if it's a small company. If it's a larger business, ask to speak to the

chief financial officer or any other person who approves credit. Introduce yourself. Show the officer the financial plan that you have prepared.

(b) *Factoring*: This is a financing method where accounts receivable of a business organization is sold to a commercial finance company to raise capital. The factor then got hold of the accounts receivable of a business organization and assumes the task of collecting the receivables as well as doing what would've been the paperwork. Factoring can be performed on a non-notification basis. It means customers may not be told that their accounts have been sold.

However, there are merits and demerits to factoring. The process of factoring may actually reduce costs for a business organization. It can actually reduce costs associated with maintaining accounts receivable such as bookkeeping, collections and credit verifications. If comparison can be made between these costs and fee payable to the factor, in many cases it has been observed that it even proved fruitful to utilize this financing method.

In addition to reducing internal costs of a business, factoring also frees up money that would otherwise be tied to receivables. This is especially true for businesses that sell to other businesses or to government; there are often long delays in payment that this would offset. This money can be used to generate profit through other avenues of the company. Factoring can be a very useful tool for raising money and keeping cash flowing.

(c) *Leasing*: Another popular method of bootstrapping is to take the equipment on lease rather than purchasing it. It will reduce the capital cost and also help lessee (person who take the asset on lease) to claim tax exemption. So, it is better to take a photocopy machine, an automobile or a van on lease to avoid paying out lump sum money which is not at all feasible for a startup organization.

Further, if you are able to shop around and get the best kind of leasing arrangement when you're starting up a new business, it's much better to lease. It's better, for example, to lease a photocopier say at ₹ 5,000 per month, rather than pay ₹ 1,00,000 for it; or lease your automobile or van to avoid paying out ₹ 5,00,000 or more.

There are advantages for both the startup businessman using the property or equipment (i.e. the *lessee*) and the owner of that property or equipment (i.e. the *lessor*.) The lessor enjoys tax benefits in the form of depreciation on the fixed asset leased and may gain from capital appreciation on the property, as well as making a profit from the lease. The lessee benefits by making smaller payments retain the ability to walk away from the equipment at the end of the lease term. The lessee may also claim tax benefit in the form of lease rentals paid by him.

(ii) **Angel Investors**: Despite being a country of many cultures and communities traditionally inclined to business and entrepreneurship, India still ranks low on comparative ratings across entrepreneurship, innovation and ease of doing business. The reasons are obvious. These include our old and outdated draconian rules and regulations which provides a hindrance to our business environment for a long time. Other reasons are red tapism, our time consuming procedures, and lack of general support for entrepreneurship. Off course, things are changing in recent times.



As per Investopedia, Angel investors invest in small startups or entrepreneurs. Often, angel investors are among an entrepreneur's family and friends. The capital angel investors provide may be a one-time investment to help the business propel or an ongoing injection of money to support and carry the company through its difficult early stages.

Angel investors provide more favorable terms compared to other lenders, since they usually invest in the entrepreneur starting the business rather than the viability of the business. Angel investors are focused on helping startups take their first steps, rather than the possible profit they may get from the business. Essentially, angel investors are the opposite of venture capitalists.

Angel investors are also called informal investors, angel funders, private investors, seed investors or business angels. These are affluent individuals who inject capital for startups in exchange for ownership equity or convertible debt. Some angel investors invest through crowdfunding platforms online or build angel investor networks to pool in capital.

Angel investors typically use their own money, unlike venture capitalists who take care of pooled money from many other investors and place them in a strategically managed fund.

Though angel investors usually represent individuals, the entity that actually provides the fund may be a limited liability company, a business, a trust or an investment fund, among many other kinds of vehicles.

Angel investors who seed startups that fail during their early stages lose their investments completely. This is why professional angel investors look for opportunities for a defined exit strategy, acquisitions or initial public offerings (IPOs).

**(iii) Venture Capital Fund:** Venture Capital Fund means investment vehicle that manage funds of investors seeking to invest in startup firms and small businesses with exceptional growth potential. Venture capital is money provided by professionals who alongside management invest in young, rapidly growing companies that have the potential to develop into significant economic contributors.

### **Venture Capitalists generally**

- Finance new and rapidly growing companies
- Purchase equity securities
- Assist in the development of new products or services
- Add value to the company through active participation.

### **Characteristics of Venture Capital Financing**

- (i) **Long time horizon:** The fund would invest with a long time horizon in mind. Minimum period of investment would be 3 years and maximum period can be 10 years.



- (ii) **Lack of liquidity:** When VC invests, it takes into account the liquidity factor. It assumes that there would be less liquidity on the equity it gets and accordingly it would be investing in that format. They adjust this liquidity premium against the price and required return.
- (iii) **High Risk:** VC would not hesitate to take risk. It works on principle of high risk and high return. So, high risk would not eliminate the investment choice for a venture capital.
- (iv) **Equity Participation:** Most of the time, VC would be investing in the form of equity of a company. This would help the VC participate in the management and help the company grow. Besides, a lot of board decisions can be supervised by the VC if they participate in the equity of a company.

### **Advantages of bringing VC in the company**

- It injects long- term equity finance which provides a solid capital base for future growth.
- The venture capitalist is a business partner, sharing both the risks and rewards. Venture capitalists are rewarded with business success and capital gain.
- The venture capitalist is able to provide practical advice and assistance to the company based on past experience with other companies which were in similar situations.
- The venture capitalist also has a network of contacts in many areas that can add value to the company.
- The venture capitalist may be capable of providing additional rounds of funding should it be required to finance growth.
- Venture capitalists are experienced in the process of preparing a company for an Initial Public Offering (IPO) of its shares onto the stock exchanges or overseas stock exchange such as NASDAQ.
- They can also facilitate a trade sale.

### **Stages of funding for VC**

1. **Seed Money:** Low level financing needed to prove a new idea.
2. **Start-up:** Early stage firms that need funding for expenses associated with marketing and product development.
3. **First-Round:** Early sales and manufacturing funds.
4. **Second-Round:** Working capital for early stage companies that are selling product, but not yet turning in a profit.
5. **Third Round:** Also called Mezzanine financing, this is expansion money for a newly profitable company.

6. **Fourth-Round:** Also called bridge financing, it is intended to finance the "going public" process.

Risk in each stage is different. An indicative Risk matrix is given below:

Financial Stage	Period (Funds locked in years)	Risk Perception	Activity to be financed
Seed Money	7-10	Extreme	For supporting a concept or idea or R&D for product development and involves low level of financing.
Start Up	5-9	Very High	Initializing prototypes operations or developing products and its marketing.
First Stage	3-7	High	Started commercials production and marketing.
Second Stage	3-5	Sufficiently high	Expanding market and growing working capital need though not earning profit.
Third Stage	1-3	Medium	Market expansion, acquisition & product development for profit making company. Also called Mezzanine Financing.
Fourth Stage	1-3	Low	Facilitating public issue i.e. going public. Also called Bridge Financing.

### VC Investment Process

The entire VC Investment process can be segregated into the following steps:

1. **Deal Origination:** VC operates directly or through intermediaries. Mainly many practicing Chartered Accountants would work as intermediary and through them VC gets the deal.

Before sourcing the deal, the VC would inform the intermediary or its employees about the following so that the sourcing entity does not waste time :

- Sector focus
- Stages of business focus
- Promoter focus
- Turn over focus

Here the company would give a detailed business plan which consists of business model, financial plan and exit plan. All these aspects are covered in a document which is called Investment Memorandum (IM). A tentative valuation is also carried out in the IM.

2. **Screening:** Once the deal is sourced the same would be sent for screening by the VC. The screening is generally carried out by a committee consisting of senior level people of the VC. Once the screening happens, it would select the company for further processing.
3. **Due Diligence:** The screening decision would take place based on the information provided by the company. Once the decision is taken to proceed further, the VC would now carry out due diligence. This is mainly the process by which the VC would try to verify the veracity of the documents taken. This is generally handled by external bodies, mainly renowned consultants. The fees of due diligence are generally paid by the VC. However, in many cases, this can be shared between the investor (VC) and Investee (the company) depending on the veracity of the document agreement.
4. **Deal Structuring:** Once the case passes through the due diligence it would now go through the deal structuring. The deal is structured in such a way that both parties win. In many cases, the convertible structure is brought in to ensure that the promoter retains the right to buy back the share. Besides, in many structures to facilitate the exit, the VC may put a condition that promoter has also to sell part of its stake along with the VC. Such a clause is called tag- along clause.
5. **Post Investment Activity:** In this section, the VC nominates its nominee in the board of the company. The company has to adhere to certain guidelines like strong MIS, strong budgeting system, strong corporate governance and other covenants of the VC and periodically keep the VC updated about certain mile-stones. If milestone has not been met the company has to give explanation to the VC. Besides, VC would also ensure that professional management is set up in the company.
6. **Exit plan:** At the time of investing, the VC would ask the promoter or company to spell out in detail the exit plan. Mainly, exit happens in two ways:
  - (a) One way is 'sell to third party(ies)'. This sale can be in the form of IPO or Private Placement to other VCs.
  - (b) The second way to exit is that promoter would give a buy back commitment at a pre agreed rate (generally between IRR of 18% to 25%). In case the exit is not happening in the form of IPO or third party sell, the promoter would buy back. In many deals, the promoter buyback is the first refusal method adopted i.e. the promoter would get the first right of buyback.

### Venture Capital Funds in India

**Evolution:** Venture Capital in India started in the decade of 1970, when the Government of India appointed a committee to tackle the issue of inadequate funding to entrepreneurs and start-ups. However, it is only after ten years that the first all India venture capital funding was started by IDBI, ICICI and IFCI.

With the institutionalization of the industry in November 1988, the government announced its guidelines in the “CCI” (Controller of Capital Issues). These focused on a very narrow description of Venture Capital and proved to be extremely restrictive and encumbering, requiring investment in innovative technologies started by first generation entrepreneur. This made investment in VC highly risky and unattractive.

At about the same time, the World Bank organized a VC awareness seminar, giving birth to players like: TDICICI, GVFL, Canbank and Pathfinder. Along with the other reforms the government decided to liberalize the VC Industry and abolish the “CCI”, while in 1995 Foreign Finance companies were allowed to invest in the country.

Nevertheless, the liberalization was short-spanded, with new calls for regulation being made in 1996. The new guidelines’ loopholes created an unequal playing ground that favoured the foreign players and gave no incentives to domestic high net worth individuals to invest in this industry.

VC investing got considerably boosted by the IT revolution in 1997, as the venture capitalists became prominent founders of the growing IT and telecom industry.

Many of these investors later floundered during the dotcom bust and most of the surviving ones shifted their attention to later stage financing, leaving the risky seed and start-up financing to a few daring funds.

Formation of venture capital has been depicted in the diagram below:

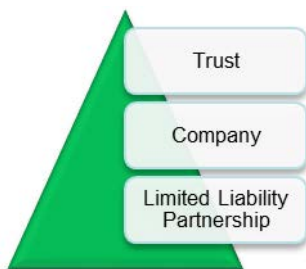

Investors in venture capital funds are shown in the following diagram:

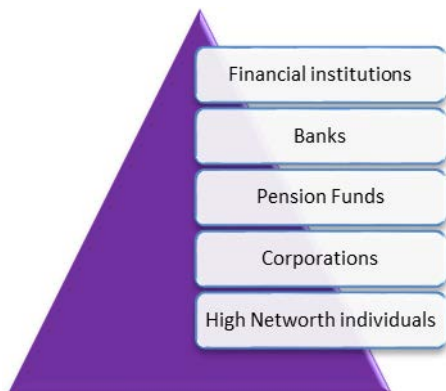

### Structure of Venture Capital Fund in India

**Structure of fund in India :** Three main types of fund structure exist: one for domestic funds and two for offshore ones:

(a) Domestic Funds : Domestic Funds (i.e. one which raises funds domestically) are usually structured as:

- i) a domestic vehicle for the pooling of funds from the investor, and
- ii) a separate investment adviser that carries those duties of asset manager.

The choice of entity for the pooling vehicle falls between a trust and a company, (India, unlike most developed countries does not recognize a limited partnership), with the trust form prevailing due to its operational flexibility.

(b) Offshore Funds : Two common alternatives available to offshore investors are: the “offshore structure” and the “unified structure”.

#### *Offshore structure*

Under this structure, an investment vehicle (an LLC or an LP organized in a jurisdiction outside India) makes investments directly into Indian portfolio companies. Typically, the assets are managed by an offshore manager, while the investment advisor in India carries out the due diligence and identifies deals.

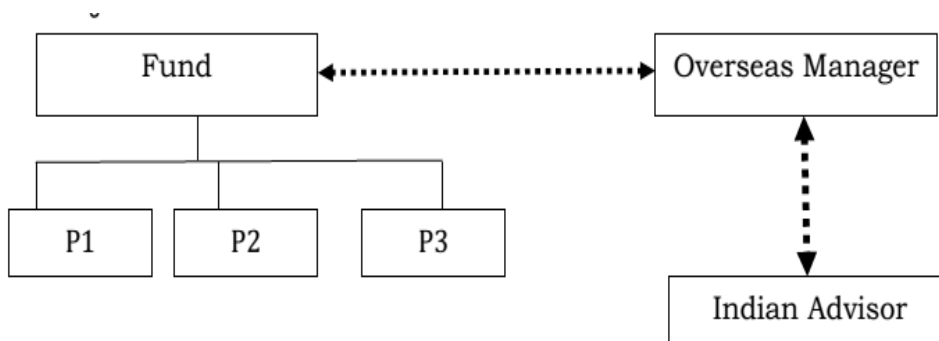

***Off shore structure***

#### *Unified Structure*

When domestic investors are expected to participate in the fund, a unified structure is used. Overseas investors pool their assets in an offshore vehicle that invests in a locally managed trust, whereas domestic investors directly contribute to the trust. This is later device used to make the local portfolio investments.

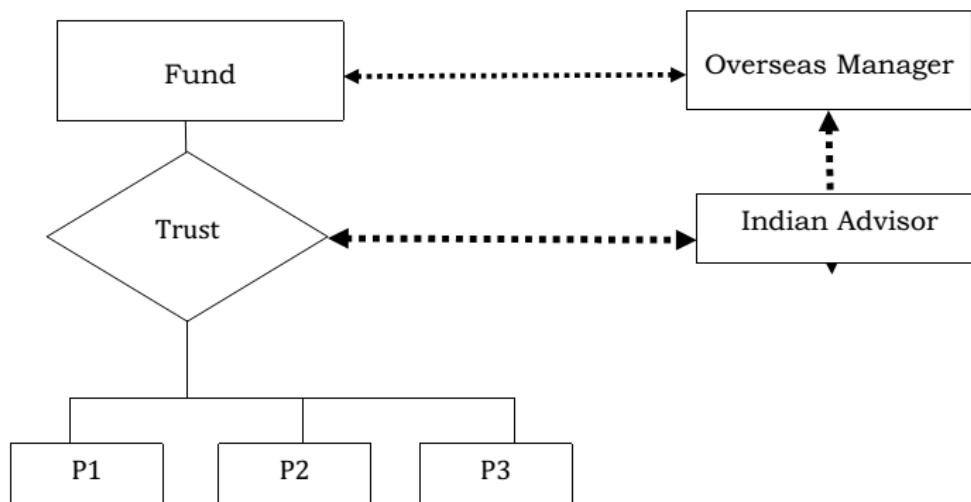

**Unified Structure**

Venture capital means funds made available for startup firms and small businesses with exceptional growth potential. Venture capital is money provided by professionals who alongside management invest in young, rapidly growing companies that have the potential to develop into significant economic contributors.

## 5. STARTUP INDIA INITIATIVE

Startup India scheme was initiated by the Government of India on 16<sup>th</sup> of January, 2016. As per GSR Notification 127 (E) dated 19<sup>th</sup> February 2019, an entity shall be considered as a Startup:

- i. Upto a period of ten years from the date of incorporation/ registration, if it is incorporated as a private limited company (as defined in the Companies Act, 2013) or registered as a partnership firm (registered under section 59 of the Partnership Act, 1932) or a limited liability partnership (under the Limited Liability Partnership Act, 2008) in India.
- ii. Turnover of the entity for any of the financial years since incorporation/ registration has not exceeded one hundred crore rupees.
- iii. Entity is working towards innovation, development or improvement of products or processes or services, or if it is a scalable business model with a high potential of employment generation or wealth creation.

Provided that an entity formed by splitting up or reconstruction of an existing business shall not be considered a 'Startup'.

**What is a Startup to avail government schemes?**



Up to 10 years from its date of incorporation / registration



Incorporated as either a Private Limited Company or a Registered Partnership Firm or a Limited Liability Partnership in India



Turnover for any fiscal year has not exceeded INR 100 crore



Entity should not have been formed by splitting up or reconstruction a business already in existence



Working towards innovation, development, deployment or commercialization of new product, processes or services driven by technology or intellectual property

Source: <http://www.startupindia.gov.in/>

## TEST YOUR KNOWLEDGE

### Theoretical Questions

1. Explain some of the innovative sources for funding a start-up.
2. What do you mean by Pitch Presentation in context of Start-up Business?

## ANSWERS/ SOLUTIONS

### Answers to Theoretical Questions

1. Please refer paragraph 2
2. Please refer paragraph 3